



TH K2 II A Coro

300 W Max Power

TECHNICAL SPECIFICATIONS		
Component	2-way system	
Size		
Woofer	mm (in.)	165 (6.5)
Tweeter diaphragm	mm (in.)	38 (1.5)
Voice Coil Ø		
Woofer	mm (in.)	50 (2)
Tweeter	mm (in.)	34 (1.34)
Power Handling	W peak	300
	W continuous	150
Sensitivity	dB SPL	87
Impedance	Ω	4
Frequency Response	Hz	40 ÷ 26k
SUGGESTED ACTIVE FILTERING: Best Envelopment <small>This set-up provides the best sound stage envelopment for listeners who prefer vertical stage well distributed along the full cabin height.</small>	Woofer	Lo-pass 2.5 kHz @ 6 dB/Oct. Butterworth, level 0 dB
	Tweeter	Hi-pass 2.75 kHz @ 12 dB/Oct. Butterworth, level -6 dB ÷ -8 dB
SUGGESTED ACTIVE FILTERING: Best Focus <small>This set-up provides the best sound stage focus for listeners who prefer vertical stage well focused above of the dashboard and a wider horizontal stage.</small>	Woofer	Lo-pass 1.25 kHz @ 12 dB/Oct. Linkwitz, level 0 dB
	Tweeter	Hi-pass 1.25 kHz @ 12 dB/Oct. Linkwitz, level -7 dB ÷ -9 dB
Weight of one component		
Woofer	kg (lb)	1.25 (2.76)
Tweeter	kg (lb)	0,355 (0.78)

ELECTRO-ACOUSTIC PARAMETERS		TH 6.5 II Sax		TH 1.5 II Violino	
				Bottom Case	Bottom Disk
D	mm	130	38	38	38
Xmax	mm	5,4	-	-	-
Re	Ω	3,8	6,1	6,1	6,1
Fs	Hz	55	780	980	980
Le	mH	0,43	0,025	0,025	0,025
Vas	l	8,6	0,019	0,013	0,013
Mms	g	24,2	0,43	0,43	0,43
Cms	mm/N	0,35	0,09	0,062	0,062
BL	T·m	8,2	3,32	3,44	3,44
Qts		0,43	0,83	0,97	0,97
Qes		0,47	1,2	1,3	1,3
Qms		5,3	2,9	3,5	3,5
Spl	dB	87	92,5	93	93

TH 1.5 II violino

- 34 mm CCAW single layer voice coil combining light weight, stability at lower frequencies and total absence of musical transients compression.
- Extremely powerful custom N38 "H-grade" Neodymium magnet providing 1.67 T·m in the magnetic gap for superb dynamic response and very low distortion in the whole frequency range.
- Exclusive air-loading system resulting in a resonance frequency below 800 Hz, for filter set-up starting as low as 1.5 kHz - 12dB/Oct.
- 38 mm natural silk dome optimized with extensive material characterization, laser vibrometer scanning and Finite Element Analysis methods for a smooth and extended response.
- Frequency response up to 26 kHz optimized for off-axis installation.
- TH 1.5 II Violino Tuning System featuring two types of electro-acoustic load: bottom case or bottom disk according to targets of highest performance as well as flexibility of in-car integration.
- Full solid metal construction structure with each part exclusively designed and produced for the Audison TH 1.5 II.
- FEM (Finite Element Method) optimized faceplate and front spokes for an improved dispersion pattern.
- eID technology providing TH 1.5 II traceability starting from the manufacturing stage up to the owner.

TH 6.5 II sax

- 50 mm mobile voice coil in CCAR (Copper Clad Aluminum Ribbon) wound with flat wire to maximize the force factor and heat dissipation.
- Low inductance of the mobile voice coil to optimize the emission in medium-high band (2-3 kHz).
- N48 "H-grade" neodymium magnet with superb thermal stability to guarantee an optimal dynamic reserve in every situation.
- Magnetic group geometry designed using finite element simulation software to maximize efficiency by concentrating the magnetic field in the gap.
- Membrane made of TPX®, a transparent material that reduces the frequency response irregularities in the mid-high band, leaving the speaker interior in full view.
- Membrane geometry designed using simulation software, to obtain a smooth emission over all the listening angles.
- Basket made of a single piece of die-cast aluminium featuring four pairs of spokes to optimize heat transfer, nullify turbulent airflows and ensure maximum structural rigidity.
- Hi-exursion suspension and spider, optimized with simulations of the loudspeaker multi-physical behavior.
- eID technology providing TH 6.5 II traceability starting from the manufacturing stage up to the owner.





TH K2 II A Coro

300 W Max Power

SUGGESTED ACTIVE FILTERING: Best Envelopment

TH K2 II CORO A - TH 6.5 II Sax + TH 1.5 II Violino Active

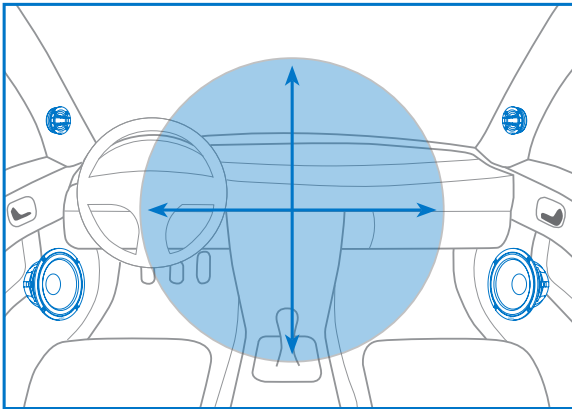

Best Envelopment

This set-up provides the best sound stage envelopment for listeners who prefer vertical stage well distributed along the full cabin height.

Tweeter Setup

Hi-pass 2.75 kHz @ 12 dB/Oct.
Butterworth, level -6 dB ÷ -8 dB

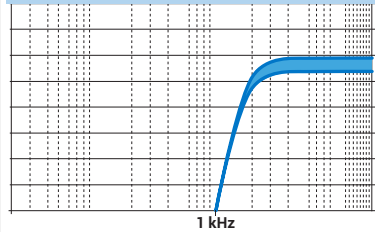

-6 dB
-8 dB

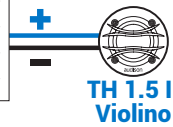

Woofer Setup

Lo-pass 2.5 kHz @ 6 dB/Oct.
Butterworth, level 0 dB

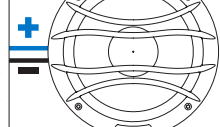
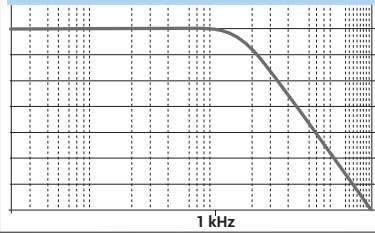

System Setup

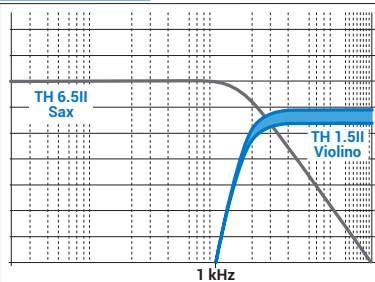

-6 dB
-8 dB



Elettromedia
62018 Potenza Picena (MC) Italy
T +39 0733 870 870 - F +39 0733 870 880
elettromedia.com





TH K2 II A Coro

300 W Max Power

SUGGESTED ACTIVE FILTERING: Best Focus

TH K2 II CORO A - TH 6.5 II Sax + TH 1.5 II Violino Active

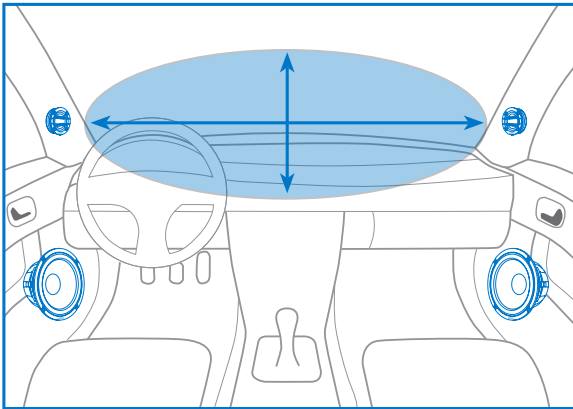

Best Focus

This set-up provides the best sound stage focus for listeners who prefer vertical stage well focused above of the dashboard and a wider horizontal stage.

Tweeter Setup

Hi-pass 1.25 kHz @ 12 dB/Oct.
Linkwitz, level -7 dB ÷ -9 dB

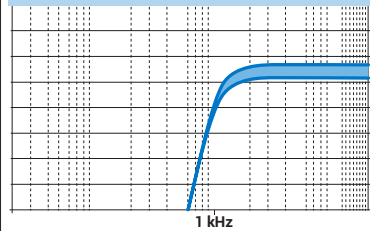

-7 dB
-9 dB



Woofers Setup

Lo-pass 1.25 kHz @ 12 dB/Oct.
Linkwitz, level 0 dB

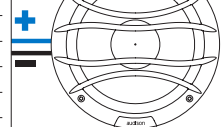
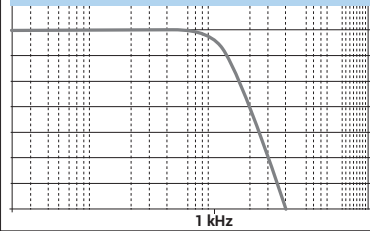

TH 6.5 II
Sax

System Setup

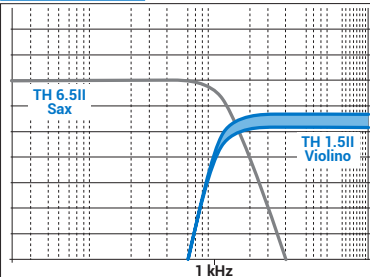

-7 dB
-9 dB